



Minuteman Horizontal Boiler Feed Units

For up to 16,000 EDR Systems

Description: **Minuteman Horizontal Pumps**

Type: **Horizontal Boiler Feed Units**

Receiver: **40-80 GAL**

Overview:

Minuteman Horizontal Boiler Feed Units establish the standard for total cost of ownership and performance. Our Boiler feed units are competitively priced but, also long term cost savings because they are built with industry standard electric motors. By building our pumps with high quality industry standards, electric motors our customers can easily make repairs with standard off the shelf components. The results is significant cost savings over the life of the unit.

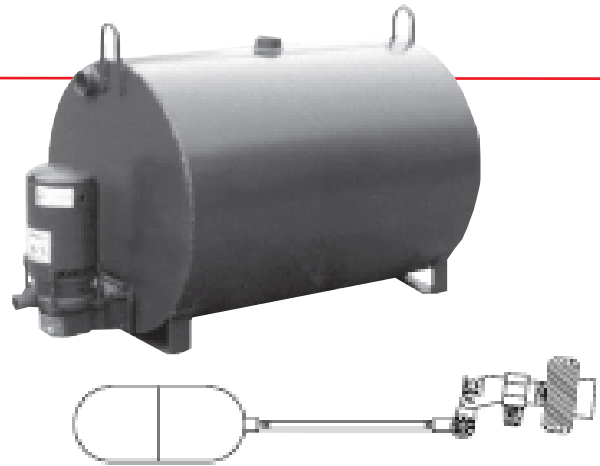

Features:

- Industry Standard Motor.
- Universal availability lowers cost and down time.
- Bronze Impeller and Wear Ring.
- Superior corrosion and wear resistance increases pump life.
- Centrifugal Technology.
- Allows pump to operate at low suction head levels.

Technical Specifications:

- Industry standard ODP 3500 RPM motors factory wired for 115 or 230/1/60 with built-in thermal overload protection. Bronze impeller and wear ring for extended pump life.
- Welded 3/16" thick steel receiver available in sizes 30 to 100 gallons. All simplex units have blank pad to convert to a duplex style if desired.
- Gauge glass assembly for viewing water level.
- Pumps are designed to efficiently pump condensate up to 200°F and mechanical seals will withstand 250°F.

How to select and order Condensate Units:

- Select unit size based on pump GPM, PSIG, and receiver size.
- First determine GPM. GPM is determined by multiplying the evaporation rate of the boiler by 1.5 to 2.0.
- Determine receiver size. Receiver size in general should be one gallon per one boiler horsepower including all boilers to be fed by the same feed unit.
- Generally low pressure boilers run at 0.5 to 15 PSIG so a 20 PSIG pump will be adequate. If unit is used as a surge tank, pumps should run continuously.
- Specify catalog number when placing order.

NES Company Inc.
31 Fairfield Place
West Caldwell, NJ 07006

(800) 297-3550
www.nescompany.com
info@nescompany.com



Minuteman Horizontal Boiler Feed Units

For up to 16,000 EDR Systems

Minuteman Horizontal Boiler Feed Units

Model	Boiler HP	System SQ FT EDR	Receiver Size	Pump (GPM)	Pump (PSIG)	Pump Type	Pump HP	# of Pumps	Pumps Discharge
MMH-049-1	40	5576	49	6	20	VM33101	1/3	1	3/4
MMH-049-2	40	5576	49	6	20	VM33101	1/3	1	3/4
MMH-070-1	60	8364	70	9	20	VM33101	1/3	1	3/4
MMH-070-2	60	9364	70	9	20	VM33101	1/3	2	3/4
MMH-117-1	100	13940	117	15	20	VM33101	1/3	1	3/4
MMH-117-2	100	13940	117	15	20	VM33101	1/3	2	3/4
MMH-180-1	120	16728	180	18	20	VM33101	1/3	1	3/4
MMH-117-2	120	16728	180	18	20	VM33101	1/3	2	3/4

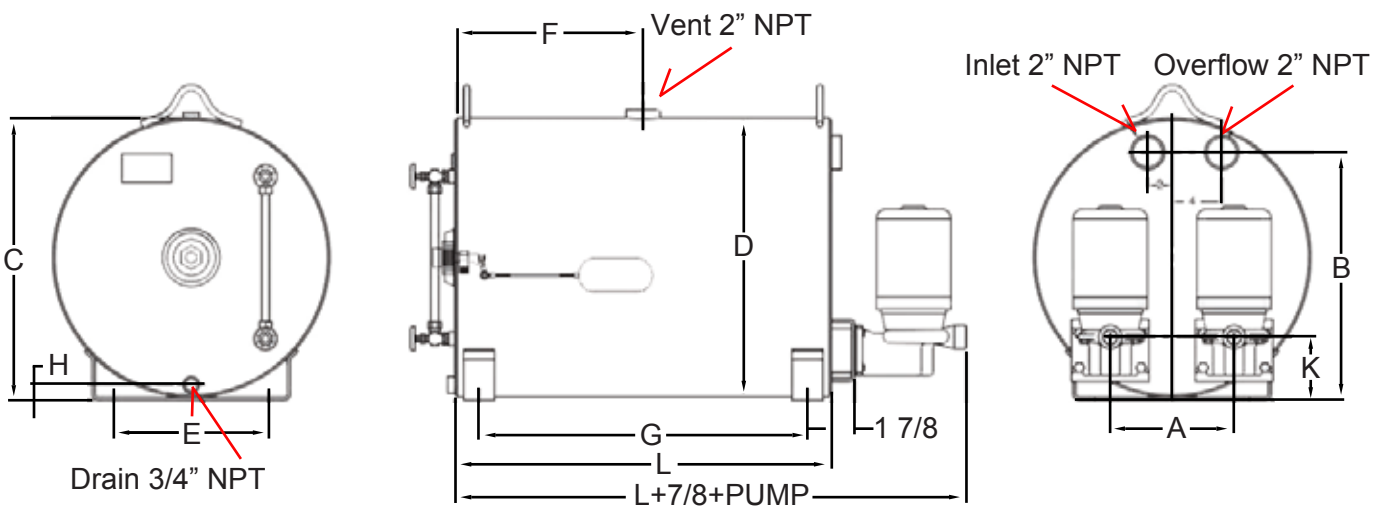

Model	Boiler HP	System SQ FT EDR	Receiver Size	Pump (GPM)	Pump (PSIG)	Pump Type	Pump HP	# of Pumps	Pumps Discharge
MMH-049-1	40	5576	49	6	20	VM33101	1/3	1	3/4
MMH-049-2	40	5576	49	6	20	VM33101	1/3	1	3/4
MMH-070-1	60	8364	70	9	20	VM33101	1/3	1	3/4
MMH-070-2	60	9364	70	9	20	VM33101	1/3	2	3/4
MMH-117-1	100	13940	117	15	20	VM33101	1/3	1	3/4
MMH-117-2	100	13940	117	15	20	VM33101	1/3	2	3/4
MMH-180-1	120	16728	180	18	20	VM33101	1/3	1	3/4
MMH-117-2	120	16728	180	18	20	VM33101	1/3	2	3/4

NES Company Inc.
31 Fairfield Place
West Caldwell, NJ 07006

(800) 297-3550
www.nescompany.com
info@nescompany.com

Rev: 0215.1
© 2018 NES Company Inc.
All rights reserved