



NHF Series Liquid Ring Vacuum Pumps

Description: Single-Stage Liquid Ring Vacuum Pump

Type: Close Coupled, Pedestal Mount, High Efficiency

Models: 50, 75, 80 & 120

Power Range: 3-7.5 HP

Capacity Range: 30-110 CFM

Max Vacuum: 27.5" Hg

Overview:

Our close-coupled high efficiency NHF Series liquid ring pumps are an excellent choice, producing up to 40% more capacity per horsepower. These new premium efficiency pumps are coupled to high efficiency IEC frame motors and have been designed from the ground-up to be interchangeable with classic Nash* AHF & MHF series pumps. NES pumps are factory tested and include a 1 year warranty



Features:

- Drop-in replacement for classic Nash* AHF & MHF series.
- Produces up to 40% more capacity per horsepower.
- Compact design reduces size & costs.
- Standard construction is Cast Iron with Stainless Steel impeller
- Optional 304 or 316 all Stainless Steel construction.
- Standard Viton mechanical seal.
- Parts and repair kits readily available.
- Available as bare pump or as a part of engineered systems.
- Standard models typically ship from stock.
- 1-year factory warranty.



Materials of Construction:

Part	Standard Material of Construction	Optional Material of Construction
Housing & Head	Cast Iron	304/316 Stainless Steel
Rotor	304 Stainless Steel	316 Stainless Steel
Port Plate	Cast Iron	304/316 Stainless Steel
Shaft	Cast Steel	
Motor	TEFC metric frame/explosion proof	230/460 Volt-3 Phase 60 Hz.

Applications:

- | | | |
|--------------|--------------------|---------------------|
| • Autoclaves | • Chucking | • Container Filling |
| • Forming | • Cooking | • Deaerating |
| • Drying | • Evaporating | • Eviscerating |
| • Exhausting | • Extruder Venting | • Fiber Setting |

NES Company Inc.
31 Fairfield Place
West Caldwell, NJ 07006

(800) 297-3550
www.nescompany.com
info@nescompany.com



NHF Series Liquid Ring Vacuum Pumps

NHF Series Liquid Ring Vacuum Pumps

Model	Max Vacuum [“Hg]	Speed [RPM]	Capacity [CFM] @ 22” Hg	Motor Power [HP]	Inlet [in]	Discharge [in]	Seal Water Usage [GPM]	Seal Water Size [in]	Pump Weight Dry [lbs.]
NHF-50	27.5	1450	28	3	2 NPT	2 NPT	1.5	1/2 NPT	80
		1750	47	3					
NHF-75	27.5	1430	55	5	2 NPT	2 NPT	3.0	1/2 NPT	90 PEDESTAL
		1750	76	5					
NHF-80	27.5	1450	58	5	2 NPT	1-1/2 FL	2.0	1/2 NPT	165
		1750	67	5					
NHF-120	27.5	1450	86	7.5	2 NPT	2 NPT	3.0	1/2 NPT	170
		1750	111	7.5					

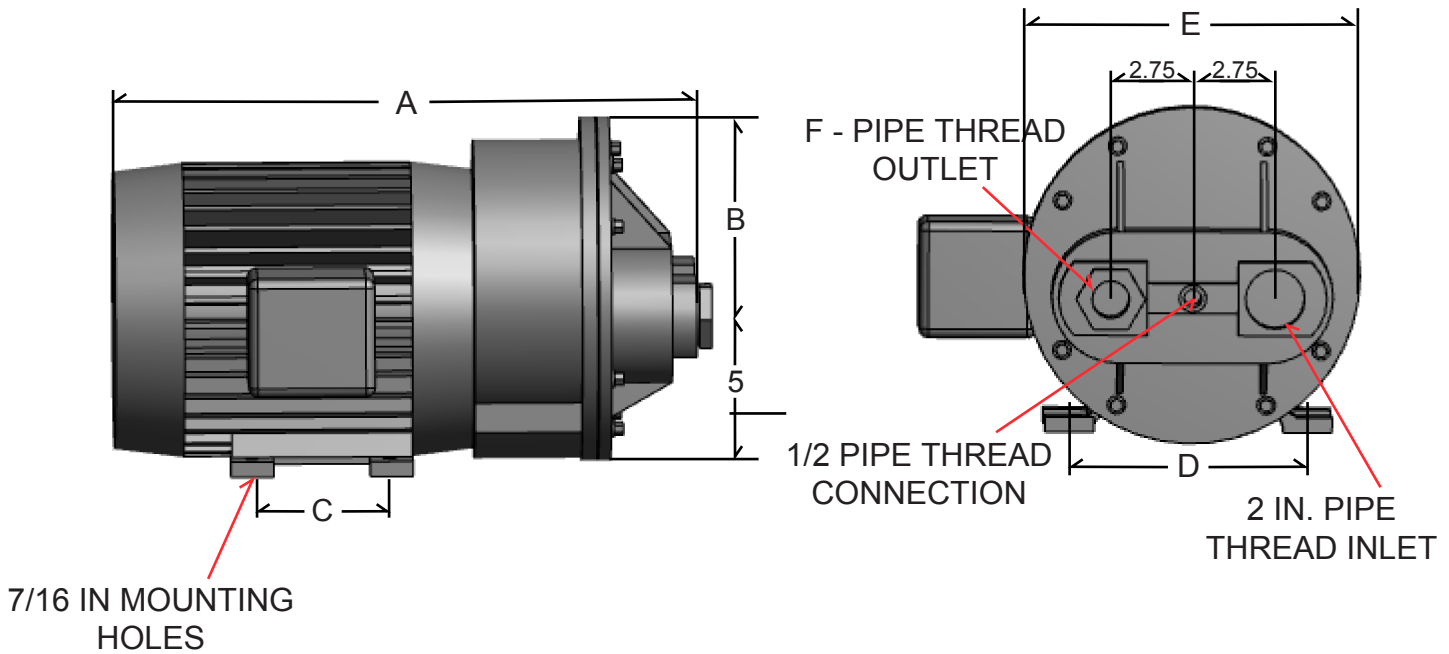

Model	A	B	C	D	E	F
NHF-50	18"	6.25"	4.5"	7.5"	11.25"	1.25"
NHF-80	20"	6.25"	5.5"	7.5"	11.25"	1.5"
NHF-120	25"	6.5"	8.5"	8.5"	11.25"	2"

TYPICAL NHF-50, 80 & 120 LAYOUTS
See pump drawing for more details & dimensions

*Nash is a registered trademark of Gardner Denver Nash. NES Company Inc. has no affiliation with Nash, Nash Engineering or Gardner Denver Nash. The information contain herein is provided as a convenience and for informational purposes only. Performance data are subject to manufacturing variation and test conditions including but not limited to atmospheric pressure, ambient temperature, seal fluid temperature, tolerances, and materials of construction. Performance of pumps constructed fully or partially of Stainless Steel may be lower due to larger clearance settings. This information may contain inaccuracies, errors or omissions. All NES Company Inc. supplied products and recommendations or suggestions must be evaluated by the end user to determine applicability and suitability for any particular use. See NES Company Inc. terms & conditions of sale for additional details which may also apply.